		General tolerance SFS-EN 2768-m		Description RACE front control arm kit		
		Welded structures EN-ISO 13920		Specification BMW E30 / E36 / E46		
Drawn By	ML	Date	17/09/2021		Number MRT-20004	Rev A
Approved By	NL	Date	18/10/2021		Material	Mass
Type		Finish				Sheet 1 / 2 A3

This document must not be copied without our written permission, and the contents thereof must not be imparted to a third party nor be used for any unauthorized purpose. Contravention will be prosecuted.

Assemble part #17 with Loctite

#	Torque rate, Nm
6, 7, 26 - 28	100
20 - 23, 29	90
24, 25	47

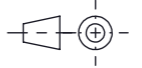
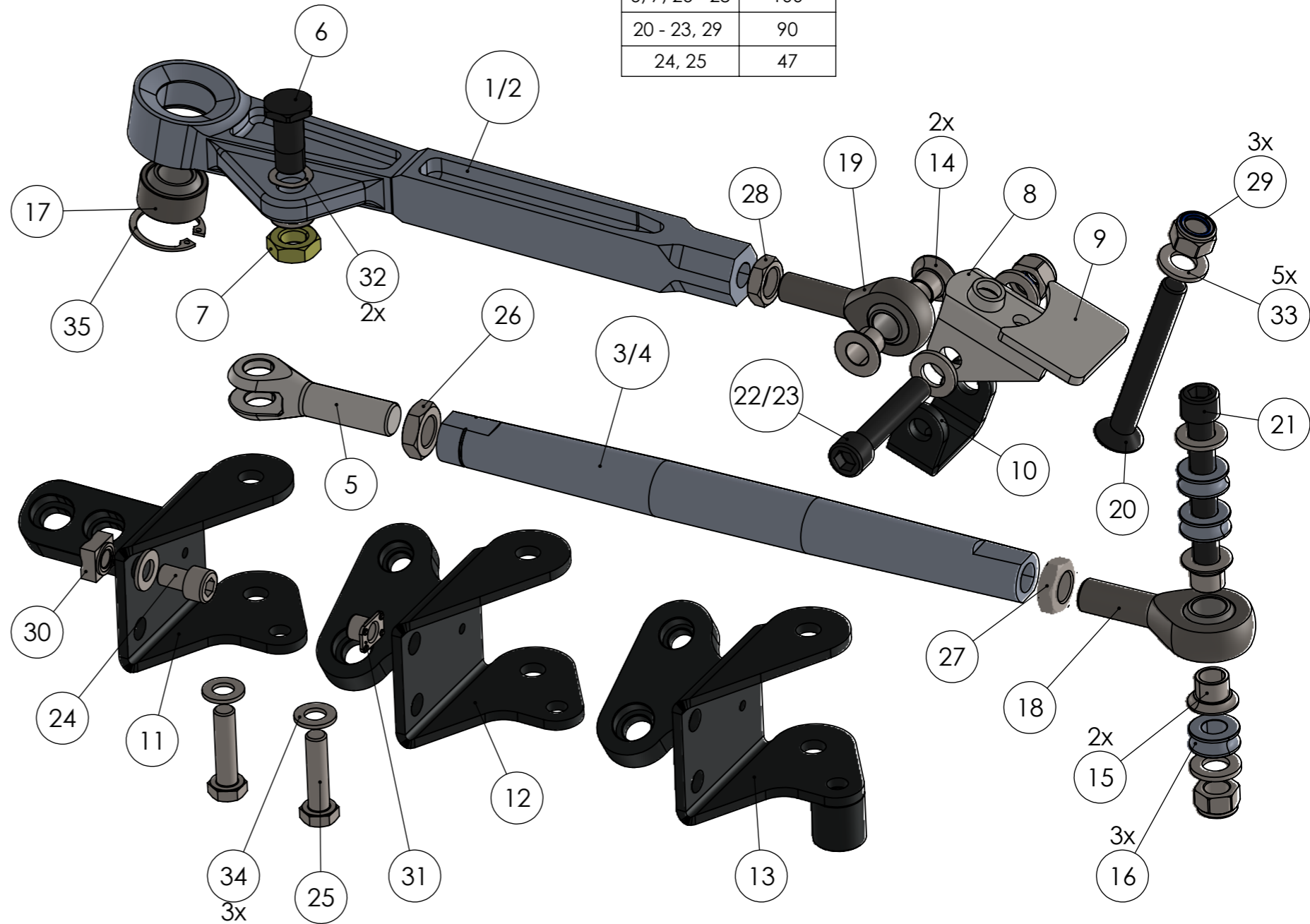

Welding required for parts #8, #9 and #30 or #31

#	PART NUMBER	DESCRIPTION	SPEC	QTY. per side
1	MRT-10004-1.1L/R	Track arm, short	E30 / E36	1
2	MRT-10004-1.2L/R	Track arm, long	E46 / +30mm	1
3	MRT-10004-2.1	Radius arm, short	E30 / E36 non-M	1
4	MRT-10004-2.2	Radius arm, long	E36 M3 / E46 / +30mm	1
5	MRT-10004-3	Clevis joint		1
6	MRT-10004-4	Titanium bolt, M14x1.5		1
7	MRT-10004-5	Titanium nut, M14x1.5		1
8	MRT-10004-6.1	Subframe bracket		1
9	MRT-10004-6.2	Subframe bracket reinforcement		1
10	MRT-10004-7	Subframe bracket extension	E46 M3	1
11	MRT-10004-8.1L/R	Rear bracket	E30 / E36	1
12	MRT-10004-8.2L/R	Rear bracket	E46 non-M	1
13	MRT-10004-8.3L/R	Rear bracket	E46 M3	1
14	MRT-10004-9.1	M14 rod end spacer		2
15	MRT-10004-9.2	M16 rod end spacer		2
16	MRT-10004-10	Anti-dive shim, 10mm		3
17	GEBJ16C	spherical bearing		1
18	XM16x1.5	rod end		1
19	XM14x1.5	rod end		1
20	DIN7991 M12x100	bolt		1
21	DIN912 M12x90	bolt		1
22	DIN912 M12x70	bolt	E46 M3	1
23	DIN912 M12x60	bolt		1
24	DIN912 M10x16	bolt		1
25	DIN933 M10x40	bolt		2
26	DIN936 M16x1.5 LH	half nut		1
27	DIN936 M16x1.5	half nut		1
28	DIN936 M14x1.5	half nut		1
29	DIN985 M12	nyloc nut		3
30	DIN928 M10	weld nut	E30	1
31	BN194 M10	spot weld nut	E36 / E46	1
32	DIN137B 14x21x0.3	wave spring washer		2
33	DIN125 M12	washer		5
34	DIN125 M10	washer		3
35	DIN472 34x1.5	circlip		1

		Description		RACE front control arm kit	
		Specification		BMW E30 / E36 / E46	
General tolerance SFS-EN 2768-m Welded structures EN-ISO 13920		Number MRT-20004		Rev A	
Drawn By ML 17/09/2021	Date 17/09/2021			Material	
Approved By NL 18/10/2021	Date 18/10/2021	Finish		Mass	Scale 1:2.5 Sheet 2 / 2 A3